

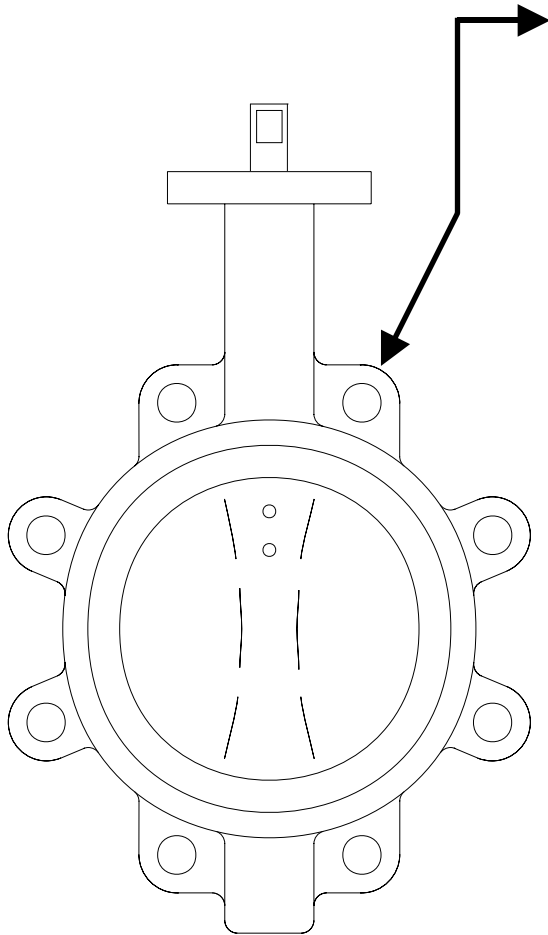

## 2"-30" Resilient Seat Butterfly Valves, ANSI 125/150 Bolt Pattern



**LUG STYLE VALVE**

Valve Size	Qty. Per Side	Thread Size	Bolt Length Lug (inch)	Req. Torque (Ft-lbs)
2"	4	5/8-11	1.250	15
2 1/2"	4	5/8-11	1.500	15
3"	4	5/8-11	1.500	15
4"	8	5/8-11	1.750	15
5"	8	3/4-10	1.750	25
6"	8	3/4-10	2.000	25
8"	8	3/4-10	2.250	25
10"	12	7/8-9	2.250	50
12"	12	7/8-9	2.500	50
14"	12	1-8	2.750	70
16"	16	1-8	2.750	70
18"	16	1 1/8 -7	3.500	100
20"	20	1 1/8 -7	4.250	100
24"	20	1 1/4 -7	4.750	150
30"	24	1 1/4 -7	4.500	150

## Valve Gaskets

In the BF Series design, the elastomer seat extends beyond the valve face and provides a leakproof seal between the valve and the mating pipe flange faces. Gaskets are not needed and should not be used when the valve is installed between standard weld neck or slip-on type flanges.

## Valve Seat Position

All BF Series valves are completely bi-directional, so installation is not dependent on seat orientation.

## Disc Clearances

Prior to installing the valve, it is important to make sure the ID of the pipe and the pipe flanges are large enough to allow the disc edge to swing into the opening without interference. Damage to the disc edge can severely affect the performance of the valve.

## Opening Rotation

The BF Series valve disc can rotate 360° without damaging the valve or elastomer seat. The valve is designed to open with either clockwise or counterclockwise rotation of the shaft.

## Installation Position

To prevent damage to the disc and seat during installation, the valve disc should be slightly open but not extending beyond the valve liner face. Positioning the disc in this "almost closed" position will reduce seat interference and initial torque build-up during valve installation.

The Series BF valves are designed to operate between two flanges. If the valve installation calls for the use of one pipe flange only, a lug style valve with the Dead End Service feature must be used.

## Valve and Flange Preparation

If the valve mating pipe are properly prepared for installation, future problems can be avoided. All valve seat and pipe flange faces should be free of dirt, grit, dents, or surface irregularities which may disrupt flange sealing and cause external leakage. The valve disc sealing surface should also be inspected to eliminate any dirt or foreign material that will adversely affect the operation of the valve.

## Installation Tools

The only tool required for the butterfly valve installation is a wrench suitable for tightening the flange bolts required to secure the valve in-line.

## Required Bolting

The table outlined on the front cover is furnished to provide information regarding the size, type, and quantity of bolting for installation.

## Unpacking and Storage Instructions

1. Check the packing list against the valve received to verify that the size, material, and trim are correct.
2. Check to make sure that the valve and operator were not damaged during shipment.
3. When lifting do not damage the flange faces or operator.
4. If the valve and operator is to be stored before being installed, it should be protected from harsh environmental conditions.
5. Keep the valve in a clean, dry, and cool location out of direct rain and sunlight.
6. If storing butterfly valves with electric actuators or electric accessories: BEWARE of moisture damage which destroys electronic components, and voids all warranty.

## Pre-Installation Procedure

1. Remove any protective flange covers from the valve.
2. Inspect the valve to be certain the waterway is free from dirt and foreign matter. Be certain the adjoining pipeline is free from any foreign material such as rust and pipe scale or welding slag that could damage the seat and disc.
3. Check the valve identification tag for materials, and operating pressure to be sure they are correct for the application.
4. Check the flange bolts for proper size, threading, and length.

## Valve Installation Procedure

Position the connecting pipe flanges in the line to insure proper alignment prior to valve installation. Spread the pipe flanges apart enough to allow the valve body to be located between the flanges without actually contacting the flange surface. Exercise particular care in handling the valves so as to prevent possible damage to the disc or seat faces

### 1. Lug style valves

- a. Place the valve between the flanges.
- b. Install all bolts between the valve and the mating flanges. Hand tighten bolts as necessary until bolts start.

#### Incorrect:

Disc opened beyond valve body face

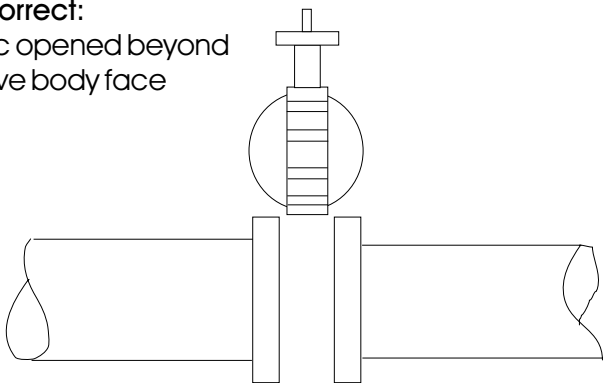

2. Before completing the tightening of any bolts, the valve should be centered between the flanges and then carefully opened and closed to insure free, unobstructed disc movement.
3. Using the sequence shown in Figure 3, tighten the flange bolts evenly to assure uniform compression.

**DO NOT TIGHTEN OVER RECOMMENDED REQUIRED TORQUE CHART ON THE FRONT COVER, HIGHER TORQUES COULD RESULT IN MOTOR FAILURE.**

4. Pneumatic or Electric connections should be made at this time as specified by the actuator installation recommendations.
5. The butterfly valve is now commissioned.

**FIGURE 3**

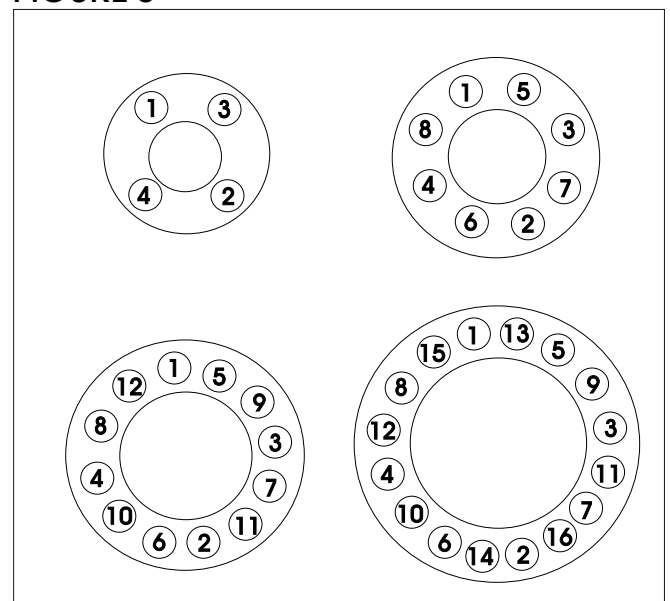

## Safety Precautions

Before removing the valve from the line or loosening any bolts, it is important to verify the following conditions:

1. Be sure the line is depressurized and drained
2. Be sure of the pipeline media.
3. Never remove the valve without an operator attached to the valve shaft.
4. Never remove the operator from the valve while the valve is in the pipeline under pressure.
5. Always be sure that the disc is in the closed position before removing the valve.

## General Maintenance

The following periodic preventative maintenance practices are recommended for all BF Series valves.

1. Operate the valve from full open to full closed to assure operability.
2. Check flange bolting for evidence of loosening and correct as needed.
3. Inspect the valve and surrounding area for previous or existing leakage at flat faced or shaft connections.
4. Check piping and/or wiring to actuators and related equipment for looseness and correct as needed.

## Butterfly Valve Disassembly

1. Position valve flat with the disc in the closed position.
2. Loosen the taper pins from the valve disc using a hammer and punch.  
**NOTE:** Punch should be of same size diameter as small end of taper pin to avoid mushrooming of taper pin.
3. Remove taper pins from disc. Extract the valve shaft from the body using a twisting motion.
4. Remove the valve disc from the body making sure not to damage the seat or disc sealing edge.
5. Cartridge seat can be removed from either-

direction by applying pressure evenly on the Face. Remove set screws in Dead End Service applications.

6. Remove shaft bushings as required.

## Butterfly Valve Assembly

1. Clean all parts, inspect for defects.
2. Apply small amounts of silicone grease to inside body and upper and lower shaft holes.
3. Insert the shaft bushings into the body being careful not to allow intrusion into the body seat bore.
4. Install the seat into the body, making sure the shaft holes in the seat line up with the body.
5. Completely coat the inside surfaces of the seat with silicone grease. Push the disc into the seat in the open position. Line up the shaft holes of the disc as close as possible with the shaft holes in the seat body.

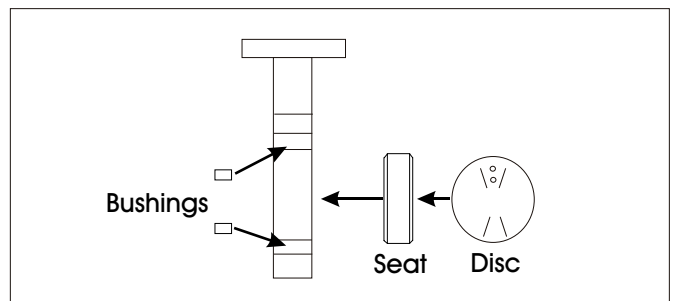

6. Insert the shaft through the body using a twisting motion to align the keyway parallel with the disc.
7. Insert taper pins in disc and set with 2 or 3 blows.
8. Dead End Service Valves must have screws inserted back into valve body.

